

Algorithmic Closed Loop Controller and Remote Channel Multifunction DAC

Overview

The VT1415A and VT1422A are C-size, single-slot, VXI modules capable of either multi-function input/output (data acquisition) or powerful control capabilities. They serve as powerful data acquisition modules that handle analog input/output and digital input/output in both static and dynamic modes. The digital capability includes the ability to set or sense static states, to measure input frequency and period, to totalize, and to input or output PWM and FM signals. Refer to the VXI Technology Website for instrument driver availability and downloading instructions, as well as for recent product updates, if applicable.

Algorithmic Closed Loop Controller - VT1415A

More powerful than PID controllers and easier to implement than large custom control systems, the VT1415A fills a unique niche in the data acquisition and control field, providing both control and precise data acquisition. Applications include:

- PID control of stimulus loops such as hydraulic actuators, levers, rotational devices as in structural test
- PID control of temperature, position, velocity, acceleration and more
- Complex control such as cascade loops in thermal cooling jackets, ratio
- Independent loops with multi-level alarms.

The design of the on-board, DSP firmware assures the user that all inputs, all calculations, and all outputs can be completed between scan triggers. This means there is no drift, or jitter in the critical time intervals that are used to calculate integrals and derivatives in control algorithms.

The firmware allows a user to employ pre-written PID control algorithms, modify them for specific application needs, or to write an application from scratch. Low duty-cycle connection to the host computer allows interaction between the host and real-time DSP so the user can update algorithms, change tuning constants, or do envelope control. Limited host computer interaction leads to very high performance (8-loops, update rate 1000/second per loop with simple PID calculation included).

Multi-function Data Acquisition & Control Module - VT1422A

The VT1422A is a module that is essentially the same as the VT1415A and has all of the same data acquisition and control capabilities as the VT1415A, plus some additional features.



Features

Powerful Data Acquisition Capability

Powerful Control Capability

Comprehensive On-board Signal Conditioning

Custom On-board DSP Program Development

Wide Choice of Input/Output Signal Types

Large Channel-count Strain Signal Conditioning and Measurement

The VT1422A Remote Channel Multi-Function DAC Module supports the VT1539A Remote Channel Signal Conditioning Plug-on and the VT1529B Remote Strain Signal Conditioning Unit to form a high-performance, but economical strain measurement system.

The VT1422A serves as the controller in this system, managing all the configuration, calibration, triggering of measurements, EU conversion, and calibration processes.

The main differences between the VT1415A and VT1422A are:

- The VT1422A has 40 kB of memory available for user algorithms; the VT1415A has 48 kB.
- If the only thing being done in an application is collection of strain data, the VT1422A user doesn't have to write an algorithm, as for the VT1415A.
- The VT1422A offers the same two Terminal Blocks as does the VT1415A.
(Option 011 screw terminals and Option 013 spring clamp)

Automated Calibration for Better Measurements

The VT1415A and VT1422A offer superior calibration capabilities that provide more accurate measurements. Periodic calibration of the module's measurement inputs is accomplished by connecting an external voltage measurement standard (such as a highly accurate multimeter) to the inputs of the module. This external standard first calibrates the on-board calibration source. Then built-in calibration routines use the on-board calibration source and on-board switching to calibrate the entire signal path from the closed loop controller's input, through the signal conditioning plug-ons (SCPs) and FET MUX, to the A/D itself. Subsequent daily or short-term calibrations of this same signal path can be quickly and automatically done using the internal calibration source to eliminate errors introduced by the signal path through the SCPs and FET MUX or by ambient temperature changes. All input channels can be quickly and productively calibrated to assure continued high-accuracy measurements.

In addition to the calibration of the signal paths within the modules, the VT1415A and VT1422A allow you to perform a "Tare Cal" to reduce the effects of voltage offsets and IR voltage drops in your signal wiring that is external to the module. The Tare Cal uses an on-board D/A to eliminate these voltage offsets. By placing a short circuit across the signal or transducer being measured, the residual offset can be automatically measured and eliminated by the D/A. Tare Cal should not be used to eliminate the thermoelectric voltage of thermocouple wire on thermocouple channels.

Algorithmic Closed Loop Controller and Remote Channel Multifunction DAC

Flexibility with Deterministic Control

The VT1415A and VT1422A are digital sampling closed loop control systems that are complete in a single VXI module. All signal conditioning, process monitoring, control calculations, and control signals are handled on-board without the need for computer supervision. Once setup is done, the module is essentially free-running.

The inputs are updated at the beginning of each cycle and the outputs are updated at a later deterministic time in the cycle so that various paths in the control algorithm do not affect the loop timing. These steps are executed automatically and deterministically without need for intervention from a system computer.

Other Features

Digital Sampling Closed Loop Control System

The VT1415A/VT1422A combine flexibility with deterministic control. Control algorithms for each of the loops can be the default PID calculation or a user-defined, downloaded, custom algorithm. The loop update rate is deterministically controlled by an internal clock so that variations in the algorithm execution times do not affect the loop cycle time.

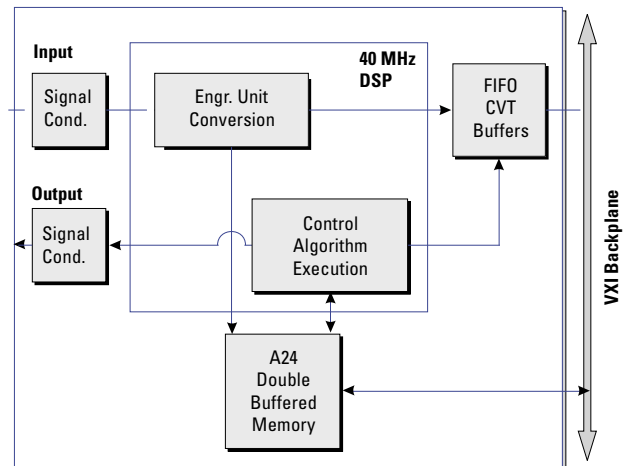

Digital Sampling Closed Loop System

Powerful Control Capability

The control algorithm for each loop is easily developed by the user from a list of algebraic expressions and flow constructs such as IF, THEN, ELSE. Tuning is simplified because all of the constants in the algorithm as well as the algorithm itself can be updated on-the-fly. New values are double-buffered so there is no need to stop scanning the inputs or halt the algorithm execution.

Algorithmic Closed Loop Controller and Remote Channel Multifunction DAC

The on-board 40 MHz pipelined DSP provides highly deterministic execution, making it easy to accurately predict cycle times. Engineering unit conversions for temperature, strain, resistance, and voltage measurements are made automatically without slowing down the algorithm execution speed.

Wide Choice of Inputs/outputs

The inputs to the loop algorithm can be measured values from multiple channels, operator input values, outputs from other loops, or values from other subsystems. The VT1415A/VT1422A have a variety of signal conditioning plug-ons for making measurements of:

- Temperature, strain
- Voltage, current, resistance
- RPM, frequency, totalize
- Discrete levels, TTL, contact closures

In addition, the measured input values and the calculated output values can be stored in a 64,000-sample FIFO buffer and efficiently transferred to the controlling computer in blocks of data. With this feature, it is no longer necessary to waste resources by dedicating a data acquisition channel to monitor each control loop input and output. The result of any algorithm calculation can be an input for use by another loop or subsystem, or it can be a direct output of several different types. Among the choices of output are:

- Analog voltage
- Analog current
- Discrete levels (TTL)
- Pulse width modulation (TTL)

As an example of output flexibility, the pulse width modulation output has several modes. In the PWM free-run mode, the frequency or pulse width output rate is independent of the loop update rate and can be changed once per loop update cycle. The square wave mode provides a variable frequency, fixed 50% duty cycle output signal. The pulse-per-update mode provides a variable width pulse synchronized to the loop update cycle.

Operator Control

Manual control can be implemented through a user software interface or external hardware, such as a potentiometer. Seamless transfer from auto to manual mode, or manual to auto is handled automatically by a set-point-tracking routine in the default PID algorithm code.

Signal Conditioning Plug-Ons

A Signal Conditioning Plug-on (SCP) is a small daughter board that mounts on VXI Technology's VXI scanning measurement and control modules. These SCPs provide a number of input and output functions. Several include gain and filtered analog inputs for measuring electrical and sensor-based signals, as well as frequency, total event count, pulse-width modulation, toothed-wheel velocity, and digital state. Output functions include analog voltage and current D/As, 8- or 16-bit digital outputs, pulse output with variable frequency and PWM, and stepper motor control.

Refer to the information on each individual SCP for more details.

Voltage Measurements

Use any of the following SCPs with the VT1415A/VT1422A to make voltage measurements: VT1501A, VT1502A, VT1503A, VT1508A, VT1509A, VT1512A, or VT1513A.

Temperature Measurements

Any of the input SCPs can be used to make temperature measurements with thermocouples, thermistors, or RTDs, but the VT1503A/VT1508A/VT1509A SCPs provide higher accuracy with thermocouples.

Resistance Measurements

Resistance is measured using either the VT1505A 8-channel Current Source SCP and an input SCP or the VT1518A 4-wire Resistance Measurement SCP. Measurements are made by applying a dc current to the unknown and measuring the voltage drop across the unknown.

Static Strain Measurements

There are two ways to make static strain measurements.

The VT1506A and VT1507A SCPs provide a convenient way to measure a few channels of static strain. When using the VT1506A/VT1507A for bridge completion, a second SCP is required to make the measurement connection. You can use the following SCPs for this type of static strain measurements:

- VT1503A 8-channel Programmable Filter/Gain
- VT1506A 8-channel 120 Ω Strain Completion & Excitation
- VT1507A 8-channel 350 Ω Strain Completion & Excitation
- VT1508A 8-channel 7 Hz Fixed Filter & x16 Gain
- VT1509A 8-channel 7 Hz Fixed Filter & x64 Gain

Algorithmic Closed Loop Controller and Remote Channel Multifunction DAC

For applications requiring large channel counts of strain measurement, the EX1629 provides a more cost effective approach to static (and dynamic) strain measurements.

Dynamic strain measurements are implemented by connecting the EX1629 to high-speed digitizers, such as the VXI Technology VT1432B and VT1433B.

Note: SCPs are also available for making dynamic strain measurements (VXI Technology VT1510A, VT1511A, and VT1521).

Transient Measurements

When making higher speed measurements, a vital issue often is the time skew between channels. Ideally, in many applications, the sampled data is needed at essentially the same instant in time. While the intrinsic design of the VT1415A/VT1422A provides scanning of 64 channels, with maximum skew of 640 μ s between the first and last channel (far less than most sampled data systems), this still may not be small enough skew for some applications.

Transient Voltage Measurements

The VT1510A provides basic sample-and-hold capabilities on four channels. Six-pole Bessel filters provide alias and alias-based noise reduction while giving excellent transient response without overshoot or ringing. The VT1510A can be used in strain applications primarily where the bridge is external.

Transient Strain Measurements

The VT1511A, a double-wide SCP, has all the capabilities of the VT1510A but adds on-board bridge excitation and completion functions. The four direct input channels are used for monitoring the bridge excitation. A maximum of four SCPs (16 channels) can be installed on a VT1415A/VT1422A.

Analog Output

Use the VT1531A for voltage outputs, and the VT1532A for current outputs. The VT1531A and VT1532A have eight (8) output channels available on each SCP.

A maximum of seven (7) VT1532A SCPs can be installed on each VT1415A/VT1422A due to power limitations. There are no power restrictions on the VT1531A.

Digital I/O

Use the VT1533A Digital I/O SCP to provide two 8-bit input/output words.

Frequency/Totalize/PWM

The VT1538A Enhanced Frequency/Totalize/PWM SCP provides eight (8) channels which can be individually configured as a frequency or totalizer input, or as a pulse width modulated output.

Compact Packaging with Signal Conditioning

The VT1415A/VT1422A provide for configurable signal conditioned I/O with up to eight individual plug-ons for analog, digital, and frequency needs. The SCPs are:

- VT1501A 8-channel Direct Input SCP
- VT1502A 8-channel 7 Hz Low-pass Filter SCP
- VT1503A 8-channel Programmable Filter and Gain SCP
- VT1505A 8-channel Current Source SCP
- VT1506A 8-channel 120 Ω Strain Completion & Excitation SCP
- VT1507A 8-channel 350 Ω Strain Completion & Excitation SCP
- VT1508A 8-channel x16 Gain & 7 Hz Fixed Filter SCP
- VT1509A 8-channel x64 Gain & 7 Hz Fixed Filter SCP
- VT1510A 4-channel Sample & Hold Input SCP
- VT1511A 4-channel Transient Strain SCP
- VT1512A 8-channel 25 Hz Fixed Filter SCP
- VT1513A 8-channel Divide-by-16 Fixed Attenuator & 7 Hz Low-pass Filter SCP
- VT1518A 4-wire Resistance Measurement SCP
- VT1521 4-channel High-speed Bridge SCP
- VT1531A 8-channel Voltage Output SCP
- VT1532A 8-channel Current Output SCP
- VT1533A 16-bit Digital I/O SCP
- VT1536A 8-bit Isolated Digital I/O SCP
- VT1538A Enhanced Frequency/Totalize/PWM SCP
- VT1539A Remote Channel SCP (VT1422A only)

Product Specifications

Algorithmic Closed Loop Controller and Remote Channel Multifunction

Timing Signals

Timing:	Scan-to-scan timing and sample-to-sample timing can be set independently.
Scan triggers:	Can be derived from a software command or a TTL level from other VXI modules, internal timer, or external hardware. Typical latency 17.5 μ s.
Synchronization:	Multiple VT1415A/VT1422A modules can be synchronized at the same rate using the TTL trigger output from one VT1415A/VT1422A to trigger the others.
Alternate synchronization:	Multiple VT1415A/VT1422A modules can be synchronized at different integer-related rates using the ALG:SCAN:RATIO command and the TTL trigger output from one VT1415A/VT1422A module to trigger the others.

Scan Triggers

Internal:	100 μ s to 6.5536 s
Resolution:	100 μ s
Trigger count:	1 to 65535 or infinite
Sample Timer Range:	VT1415A: 10 μ s to 32768 ms VT1422A: 40 μ s to 32768 ms
Resolution:	0.5 μ s

Measurement Specifications

The following specifications include the SCP and scanning A/D performance together as a unit. Accuracy is stated for a single sample. Averaging multiple samples will improve accuracy by reducing noise of the signal. The basic VT1415A scanning A/D has a full-scale range of ± 16 V and five auto-ranging gains of x1, x4, x16, x64, and x256. An SCP must be used with each eight channel input block to provide input protection and signal conditioning.

Note: For field wiring, the use of shielded twisted pair wiring is highly recommended.

Measurement resolution: 16 bits (including sign)

Maximum reading rate: VT1415A: Up to 56 kSa/s dependent upon configuration
VT1422A: Up to 25 kSa/s dependent upon configuration

Memory: 64 kSamples

Maximum input voltage: Normal mode plus common mode

Operating: ± 16 V peak
Damage level: ± 42 V peak

Maximum common mode voltage:

Operating: ± 16 V peak
Damage level: ± 42 V peak

SCP input impedance: 100 M Ω differential

Maximum tare cal offset: 62.5 mV range $\pm 75\%$ of full scale, other ranges $\pm 25\%$ of full-scale

Jitter:

Phase jitter scan-to-scan: 80 ps rms

Phase jitter card-to-card: 41 ns peak 12 ns rms

Measurement Accuracy

Typically $\pm 0.01\%$ of input level; varies with the SCP used. Specifications are 90 days, 23 $^{\circ}$ C ± 1 $^{\circ}$ C, with *CAL done after a 1 hr warm-up and CAL:ZERO done within 5 minutes. Note: Beyond the 5min. limitation and CAL:ZERO not done, apply the following drift error: Drift = 10 μ V/ $^{\circ}$ C \div SCP gain, per $^{\circ}$ C change from CAL:ZERO temperature.

Accuracy Data

Measurement accuracy is dependent upon the SCP module used. Refer to the accuracy tables and graphs for the individual SCP to determine the overall measurement accuracy.

Many definitions of accuracy are possible. Here we use single-shot with 3 sigma noise. To calculate accuracy assuming temperature is held constant within ± 1 $^{\circ}$ C of the temperature at calibration, the following formula applies:

$$\text{Single Shot } 3\sigma = \pm\sqrt{(\text{GainError})^2 + (\text{OffsetError})^2 + (3\sigma \text{ noise})^2}$$

Correcting for Temperature

Algorithmic Closed Loop Controller and Remote Channel Multifunction

To calculate accuracy over temperature range outside the ± 1 °C range, results after *CAL are given by replacing each of the above error terms as follows:

Replace $(GainError)^2$
with $(GainError)^2 + (GainTempco)^2$

Replace $(OffsetError)^2$
with $(OffsetError)^2 + (OffsetTempco)^2$

Loop Control Specifications

Number of loops: 1 to 32

Default control algorithm type: PID

Maximum VT1415A loop update rate for default PID algorithm:

(Note: VT1422A maximum sample rate is 25 kSamples/s, compared to 56 kSa/s for the VT1415A. The loop speeds of the VT1422A are reduced in same ratio.)

1 loop:	3 kHz
8 loops:	1 kHz
32 loops:	250 Hz

Custom algorithm development:

Language: Subset of C programming language including if-then-else, most math and comparison operations.

Variable types: Scalar local and global

variables, array local and global variables.

Intrinsic functions:

interrupt(), writefifo(), writecv(), writeboth(), min(), max(), abs().

Other functions:

Create own custom functions to handle transcendental operations.

I/O General

A total of eight (8) Signal Conditioning Plug-ons (SCPs) can be installed in most combinations of input or output configurations on a single VT1415A/VT1422A.

Power Available for SCPs

± 24 V:	1.0 A
5 V:	3.5 A

General Specifications

VXI device type: A16, slave only, Register based

Size: C

Slots: 1

Connectors: P1/2

Shared memory: n/a

VXI buses: TTL Trigger bus

Drivers: VXIplug&play with Source Code

Instrument Drivers - See the VXI Technology Website www.vxitech.com for driver availability and downloading.
VT1415A Algorithmic Closed Loop Controller,

Algorithmic Closed Loop Controller and Remote Channel Multifunction

Ordering Information

	Includes Spring Clamp Terminal Block	VT1415A-02	Algorithmic Closed Loop Controller, Includes Screw Connector Terminal Block
	VT1415A-A3F		Interface to rackmount terminal panel
	VT1422A		Remote Channel Multi-function Data Acquisition & Control Module
	VT1422A-001		16-Port RJ-45 Connector Block (supports VT1415A also)
	VT1422A-011		Screw Terminal Connector Block (supports VT1415A also)
	VT1422A-013		Spring Clamp Terminal Connector (supports VT1415A also)
	VT1501A		8-channel Direct Input SCP
	VT1502A		8-channel 7 Hz Low-pass Filter SCP
	VT1503A		8-channel Programmable Filter/Gain SCP
	VT1505A		8-channel Current Source SCP
	VT1506A		8-channel 120 Ω Strain Completion & Excitation SCP
	VT1507A		8-channel 350 Ω Strain Completion & Excitation SCP
	VT1508A		8-channel x16 Gain & 7 Hz Fixed Filter SCP
	VT1509A		8-channel x64 Gain & 7 Hz Fixed Filter SCP
	VT1510A		4-channel Sample & Hold Input SCP
	VT1511A		4-channel Transient Strain SCP
	VT1512A		8-channel 25 Hz Fixed Filter SCP
	VT1513A		8-channel \div 16 Fixed Attenuator & 7 Hz Low-pass Filter SCP
	VT1518A		4-wire Resistance Measurement SCP
	VT1521		4-channel High-Speed Bridge SCP
	VT1531A		8-channel Voltage Output SCP
	VT1532A		8-channel Current Output SCP
	VT1533A		16-bit Digital I/O SCP
	VT1536A		8-bit Isolated Digital I/O SCP
	VT1538A		Enhanced Frequency/Totalize/PWM SCP
	VT1539A		Remote Channel Signal Conditioning Plug-on (VT1422A only)

VT1415A/VT1422A

ACCESSORIES

- 73-0025-002 Option 011 Screw Terminal Connector Block
- 73-0025-003 Option 013 Spring Clamp Terminal Connector Block
- 73-0025-004 Option A3F Interface to Rackmount Terminal Panel

